

# Use of Dispersion Compensating Fiber in Optical Transmission Network for Triangular Modulation Format

Navdeep Kaur<sup>1</sup>, Ranvir Kaur<sup>2</sup>, Gurpreet Kaur<sup>3</sup>

<sup>1,3</sup>Department of ECE, Baba Banda Singh Bahadur Engineering College, Fatehgarh Sahib, Punjab

<sup>2</sup>Department of EE, Baba Banda Singh Bahadur Engineering College, Fatehgarh Sahib, Punjab

**Abstract**— In this paper; dispersion compensating fibers are used to compensate for the positive dispersion accumulated over the length of fiber. Post dispersion compensation scheme is employed for dispersion compensation. TRIANGULAR modulation format is employed. The performance of this scheme is analyzed and then the optimization of this scheme is done by different wavelengths of C band. The investigation is done on detailed simulative analysis using opt system.

**Keywords**— Dispersion compensating fiber, Dispersion, Q-Factor, Bit Error Rate, Single mode fiber.

## I. INTRODUCTION

The Optical fiber communications have changed our lives in many ways over the last four decades there is no doubt that low-loss optical transmission fibers have been critical to the enormous success of optical communications technology. There is no doubt that low loss optical transmission fibers have been critical to the enormous success of optical communications technology. In the telecommunication sector, the so-called passive optical network was proposed for the already envisioned fiber-to-the-home (FTTH) network. This network relied heavily on the use of passive optical splitters. These splitters were fabricated from standard single-mode fibers (SMFs). Although FTTH, at a large scale, did not occur until decades later, research into the use of components for telecommunications applications continued. The commercial introduction of the fiber optic amplifier in the early 1990s revolutionized optical fiber transmissions. With amplification, optical signals could travel hundreds of kilometers without regeneration [1]. The performance of any communication system is ultimately limited by the signal-

to-noise ratio (SNR) of the received signal and available bandwidth. This limitation can be stated more formally by using the concept of *channel capacity* introduced within the framework of information theory [2].

## II. THE EFFECT of FIBER-OPTIC DISPERSION ON OPTICAL TRANSMISSION

Loss and dispersion are the major factor that affect fiber-optical communication being the high-capacity develops. The EDFA is the gigantic change happened in the fiber-optical communication system; the loss is no longer the major factor to restrict the fiber-optical transmission. Since EDFA works in 1550 nm wave band, the average Single Mode Fiber (SMF) dispersion value in that wave band is very big, about 15-20ps / ( nm. km-1). It is easy to see that the dispersion become the major factors that restrict long distance fiber-optical transfers [3]. Dispersion is defined as because of the different frequency or mode of light pulse in fiber transmits at different rates, so that these frequency components or models receive the fiber terminals at different time. It can cause intolerable amounts of distortions that ultimately lead to errors.

In single-mode fiber performance is primarily limited by chromatic dispersion which occurs because the index of the glass varies slightly depending on the wavelength of the light, and light from real optical transmitters necessarily has non zero spectral width (due to modulation)[4,5].

## III. DCF DISPERSION COMPENSATION TECHNOLOGY

In order to improve overall system performance and reduced as much as possible the transmission performance influenced by the dispersion, several dispersion

compensation technologies were proposed [6]. Amongst the various techniques proposed in the literature, the ones that appear to hold immediate promise for dispersion compensation and management could be broadly classified as: dispersion compensating fibers (DCF), chirped fiber Bragg gratings (FBG), and high-order mode (HOM) fiber [7]. The idea of using dispersion compensation fiber for dispersion compensation was proposed as early as in 1980 but, until after the invention of optical amplifiers, DCF began to be widespread attention and study. As products of DCF are more mature, stable, not easily affected by temperature, wide bandwidth, DCF has become a most useful method of dispersion compensation.[8]

#### IV. DISPERSION COMPENSATION SCHEME EMPLOYED

The use of dispersion compensating fiber is an efficient way to upgrade installed links made of standard single mode fiber. Conventional dispersion compensating fibers have a high negative dispersion -70 to -90 ps/nm.km and can be used to compensate the positive dispersion of transmission fiber in C band. Of particular interests are the pre-, post- and symmetrical compensation techniques where each link is made of spans where the DCF is located before, after the SMF or symmetrically across the SMF. A DCF module should have low insertion loss, low polarization mode dispersion and low optical nonlinearity. [9]

By placing one DCF with negative dispersion after a SMF with positive dispersion, the net dispersion will be zero

$$D_{SMF} \times L_{SMF} = - D_{DCF} \times L_{DCF}$$

Where D and L are the dispersion and length of each fiber segment respectively.

Fiber based Compensation is done by two methods:

- i) Pre-Compensation
- ii) Post Compensation

**Pre-Compensation:** The optical communication system is pre compensated by the dispersion compensating fiber of negative dispersion against the standard fiber.

**Post-Compensation:** The optical communication system is post compensated by the dispersion compensating fiber of negative dispersion against the standard fiber. [10]

Among these two methods, post compensation model can transmit low power signal at a much higher bit rate, to a longer distance maintain a higher quality of the signal than post compensation.[11]

#### V. SYSTEM SET UP AND SIMULATION DETAILS

The transmitter section consists of data source, modulator driver (TRIANGULAR driver), laser source (CW laser) and amplitude modulator. Data source produces a pseudo-random sequence of bits at a rate of 30 Gbit/s. The output of data source is given to modulator driver which produces TRIANGULAR format pulse with duty cycle of 0.5. The output of laser source is CW type. The line-width was set to 10 MHz full width half maximum. The modulator is of Mach-zehnder modulators have the Excitation ratio 30db. The loop control system has only one loop. Each span consists of 100 km of transmission fiber (SMF) and 21 km DCF in order to fully compensate for the dispersion slope and accumulated dispersion in the transmission fiber. The parameters for DCF are attenuation 0.3db/km and dispersion -80ps/nm/km. The SMF have the reference wavelength of 1550nm with attenuation 0.3dB/km and Dispersion 17ps/nm/km. The input powers of transmission fiber and DCF are varied independently from each other to find the maximum reach limit. Two EDFAs in front of transmission fiber and DCF with 6.6 dB gain and 4 dB noise figures each are used to adjust input power levels. At the receiver side, the optical signal is transformed in to an electrical signal by a PIN photodiode. The PIN photo detector have the Responsivity 1A/W and Dark current 10nA. The electrical signal is filtered by a low pass Bessel filter with Sweep value of Cut frequency "0.7\*Bit rate" Hz. The simulation set up for post compensation scheme is as shown in Figs.1.

The length of dispersion compensated fiber is taken as 21 km and that of single mode fiber is taken as 100 km and EDFAs with 4 dB noise figure are used and these are modeled by wavelength independent gain and noise addition.. The simulation is done with optsim software which is an advanced optical communication system simulation package designed for professional engineering and cutting-edge study of WDM, DWDM, TDM, CATV, optical LAN, parallel optical bus, and other emerging

optical systems in telecom, data communication, and other applications.

**VI. RESULTS AND ANALYSIS**

In optical communication systems, only optical signal to noise ratio (OSNR) could not accurately measure the system performance, especially in WDM systems. Typically, as a quality factor, Q is a one of the important indicators to measure the optical performance by which to characterize the BER.

Figure 2 give the simulation results at different frequencies. The eye diagram is a common indicator of performance in digital transmission systems. The eye diagram is an oscilloscope display of a digital signal, repetitively sampled to get a good representation of its behavior. In a radio system, the point of measurement may be prior to the modulator in a transmitter, or following the demodulator in a receiver, depending on which portion of the system requires examination. As we can see from the figure 2, the effect of dispersion compensation is very good. The signal quality is high, eye's shape is very good, and the edge neat graph is symmetrical. And the effect of dispersion compensation is quite good. The curve of Q-factor changes with the open degree of eye diagram as follows: More approaches the point of largest eye diagram opened, the Q-factor is bigger, and the Corresponding BER is smaller. Figure 2 shows at the largest eye diagram opened, the Q-factors of the six channels achieve about 6. The figure shows this system have the big decision scope under the guarantee of the condition of system bit error rate. The eye diagram can also be used to examine signal integrity in a purely digital system—such as fiber optic transmission, network cables or on a circuit board.

In a digital optical telecommunications receiver, the incident signals are sampled in the centre of the bit period and the sampled level is compared to a threshold to determine the presence of a one or zero. With threshold detection of this nature errors arise when noise in the system pulls a one signal level below threshold at the sampling point and pushes a zero above threshold.

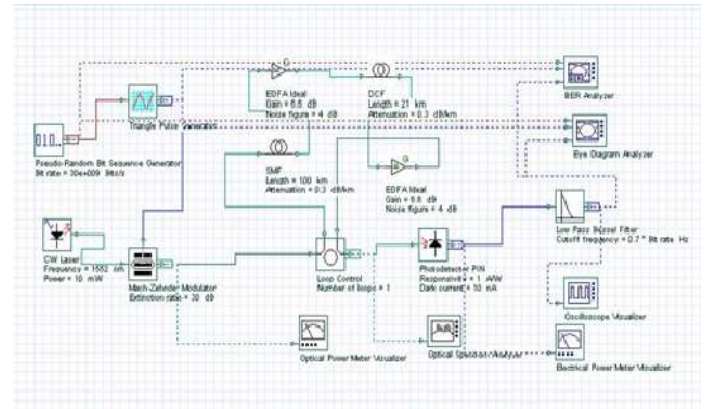
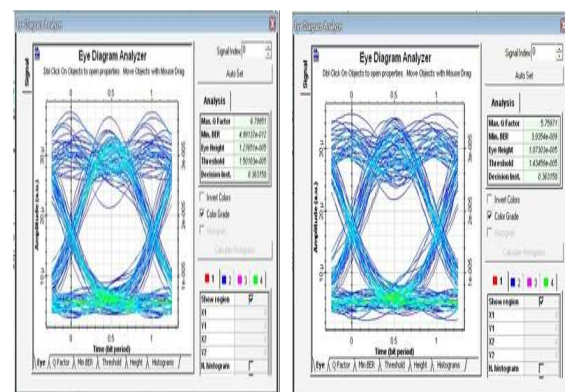

Fig. 1 Schematic for Post Compensation Scheme

Table 1 shows the values of the BER and Q-factor for the different frequencies of the C-Band at power of 10mW.

TABLE I VALUES of BER and Q-Factor for DIFFERENT FREQUENCES of C-BAND

WAVELENGTH (nm) with power 10mW	Min BER (30 Gb/s)	Q factor
1550	4.99137 e-012	6.79951
1551	3.9354 e-009	5.75971
1552	8.4402 e-010	6.02207
1553	2.31419 e-010	6.22698
1555	1.38349 e-009	5.93579
1560	2.19439 e-010	6.22994



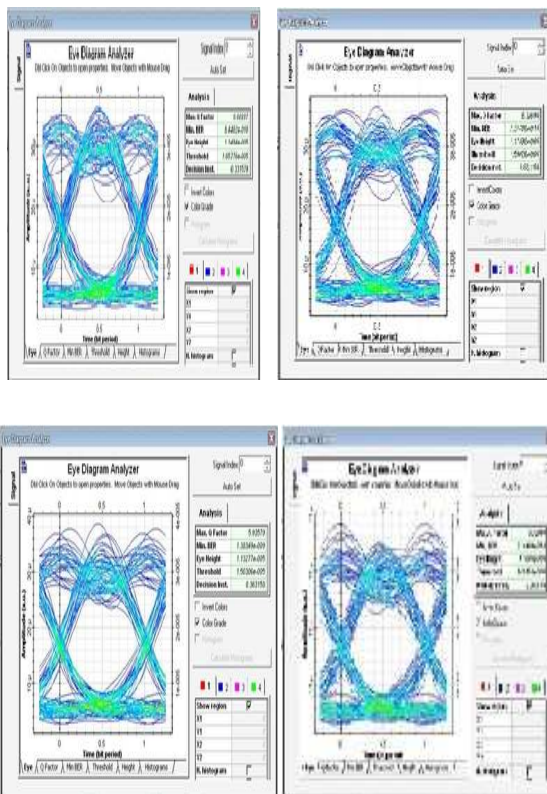

Fig 2 Eye diagrams at different frequencies

BER is the function of system quality factor  $Q$ . The quality factor is an electrical domain measure of ratio of separation between digital states to the noise associated with the state.  $Q$ -factor decides the performance of system parameter such as accumulated optical noise generated by optical amplifiers, polarization dependent losses and polarization mode dispersion occurred in the channel in long haul transmission.

The bit error rate (BER) is the most significant performance parameter of any digital communications system. It is a measure of the probability that any given bit will have been received in error. For example a standard maximum bit error rate specified for many systems is  $10^{-10}$ . This means that the receiver is allowed to generate a maximum of 1 error in every  $10^{10}$  bits of information transmitted or, putting it another way, the probability that any received bit is in error is  $10^{-10}$ .

## VII. CONCLUSION

In this paper, the modulation format TRIANGULAR is investigated in a repeated 30 Gbit/s dispersion managed system based on 121 km fiber spans. Dispersion Compensation scheme employed was post dispersion

compensation scheme. Input power levels of SMF are DCF are optimized. Existence of transmission optimum is clearly observed from contour plots. After optimizing post dispersion compensation scheme, SINE modulation format is better at 1550nm.  $Q$  factor obtained in this wavelength is about 6 which are better than among other wavelengths of the C band.

## REFERENCE

- [1] Ming-Jun Li, Xin Chen, Daniel A. Nolan, Ji Wang, James A. West, and Karl W. Koch, —Specialty fibers for optical communication systems| Optical Fiber Telecommunications V A: Components and Subsystems, 2008, Elsevier.
- [2] C. E. Shannon, —A mathematical theory of communication,| Bell Syst. Tech. J., vol. 27, pp. 379–423, 623–656, 1948.
- [3] Wu Qiang, Yu Chong Xiu, "Analysis on dispersion compensation with DCF", semiconductor optoelectronics, Vol.24 No.3 pp.186-196. June 2003
- [4] Zhaohuaigang, "study on dispersion compensation in optical transmission system", study on optical communications, Vol.3, No.141, 2007
- [5] Wangchen, Raomin, "the performance of the DCF transmission system", Journal of applied sciences, Vol.21, No.2, pp.177-181, June 2003
- [6] Djafar K. Mynbaev Lowell and L. Scheiner, "Fiber-optic communications technology" Beijing, Science publishing company, 2002
- [7] Jianjun Yu, Bojun Yang, "Dispersion-allcated soliton technology with long amplifier spacing and long distance," IEEE photon technol lett, vol 9, pp. 952-954, No.7, 1997:
- [8] Zhou ZhiQiang, Tang YuLiang, "Optimum schemes of dispersion compensation transmission systems using dispersion compensation fibers", laser technology, Vol.24, No.5, pp.265-269 Oct.2000
- [9] Kikuchi, N. Sasaki, S. and Sekine, K. "10 Gbit/s dispersion compensated transmission over 2245 km conventional fibers in recirculating loop" IET Electronics Letters, vol. 31(5), pp. 375-377, 1995
- [10] Rothnie, D.M. and Midwinter J.E. , "Improved standard fiber performance by positioning the

dispersion compensating fiber” IET Electronics Letters,  
vol. 32(20), pp. 1907-1908,1996

- [11] Mir Zayed Shames, “Signal Quality of Dispersion managed Quasi –linear high bit rate optical transmission system,” in IJECET, vol.4, pp. 108-114, june 2013.